

GERADE ELEKTRODENSCHÄFTE

ISO 5183_1

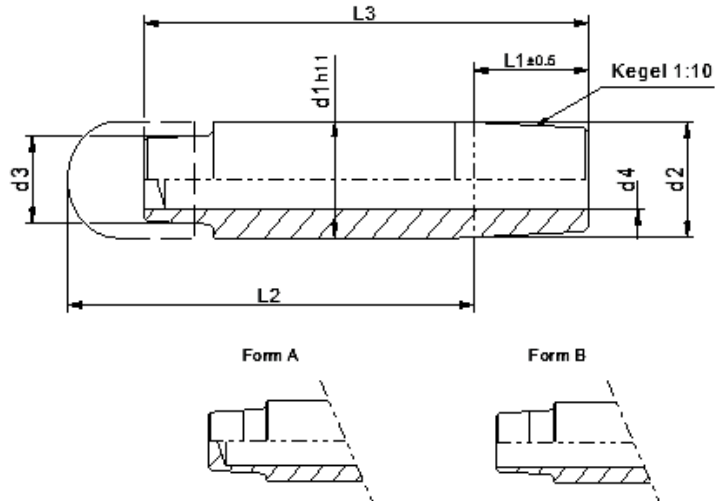

Bezeichnung	d1	L3	d2	d3	d4	L1	L2
ISO 5183 - 1 - (A/B) -	13 x	36,0	12,7	10,0	6,5	16,0	31,5
ISO 5183 - 1 - (A/B) -	13 x	44,5					40,0
ISO 5183 - 1 - (A/B) -	13 x	54,5					50,0
ISO 5183 - 1 - (A/B) -	13 x	67,5					63,0
ISO 5183 - 1 - (A/B) -	13 x	84,5					80,0
ISO 5183 - 1 - (A/B) -	13 x	104,5					100,0
ISO 5183 - 1 - (A/B) -	13 x	129,5					125,0
ISO 5183 - 1 - (A/B) -	16 x	48,0	15,5	12,0	8,0	20,0	40,0
ISO 5183 - 1 - (A/B) -	16 x	58,0					50,0
ISO 5183 - 1 - (A/B) -	16 x	71,0					63,0
ISO 5183 - 1 - (A/B) -	16 x	88,0					80,0
ISO 5183 - 1 - (A/B) -	16 x	108,0					100,0
ISO 5183 - 1 - (A/B) -	16 x	133,0					125,0
ISO 5183 - 1 - (A/B) -	16 x	168,0					160,0
ISO 5183 - 1 - (A/B) -	20 x	63,0	19,0	15,0	10,5	25,0	50,0
ISO 5183 - 1 - (A/B) -	20 x	76,0					63,0
ISO 5183 - 1 - (A/B) -	20 x	93,0					80,0
ISO 5183 - 1 - (A/B) -	20 x	113,0					100,0
ISO 5183 - 1 - (A/B) -	20 x	138,0					125,0
ISO 5183 - 1 - (A/B) -	20 x	173,0					160,0
ISO 5183 - 1 - (A/B) -	20 x	213,0					200,0