

GEKRÖPFTE PUNKTSCHWEISSELEKTRODEN

Elektrodenform E

Aufnahme-Konus	d1	d2	d3	d4	l1	l2	A	Teile-Nr.
MK1	16	12,065	6,5	7	100	25	40	1 E-100
MK2	20	17,780	9	8	115	35	45	2 E-115
	25					22	50	2 E-115/25
MK3	25	23,826	11	10	130	45	60	3 E-130

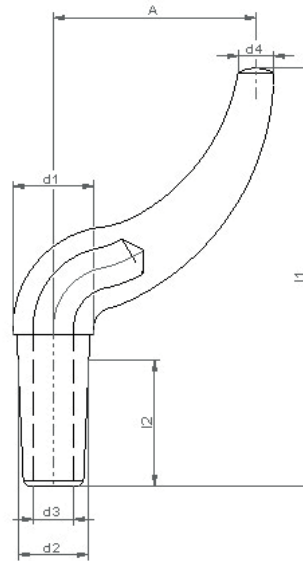

Elektrodenform G

Aufnahme-Konus	d1	d2	d3	d4	l1	l2	A	Teile-Nr.
MK1	12,5	12,065	8	4	55	14	25	1 G-55
MK2	18,5	17,780	10	6	70	22	30	2 G-70

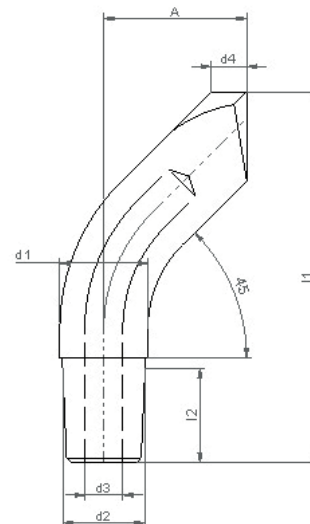

Elektrodenform G 1

Aufnahme-Konus	d1	d2	d3		l1	l2	A	Teile-Nr.
MK1	12,5	12,065	8		55	14	25	1 G 1-55
MK2	18,5	17,780	10		70	22	30	2 G 1-70

